

Class 150 Stainless Steel/Carbon Steel Ball Valves

Full bore, Split body, Side entry design

● Conform to NACE MR0175 for hardness of body, body cap, stem and ball.

Features

- Antistatic device
- Blowout-proof stem
- Fire test certification★(API 607, ISO 10497)
- Stem head conform to CAPI ADDS 2.02 dimensions
- High performance **HYPATITE® PTFE** ball seats
- Actuator mounting pad to ISO 5211

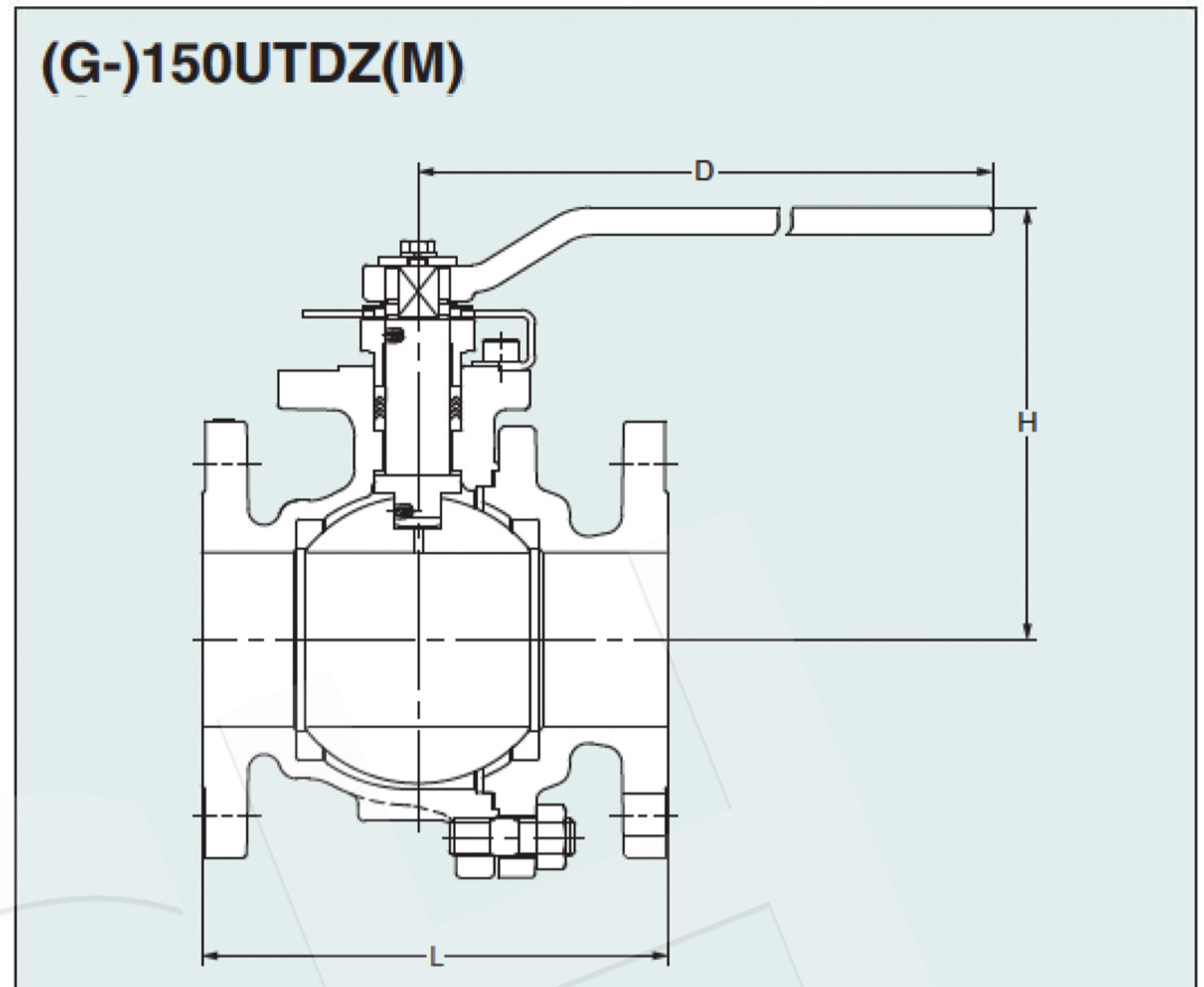

Dimensions of 150UTDZ(M), 150SCTDZ

Unit: mm

Nominal Size	NPS	1/2	3/4	1	1 1/4*	1 1/2	2	2 1/2	3	4	5	6	8	10
	DN	15	20	25	32*	40	50	65	80	100	125	150	200	250
Ball bore		14	19	24	32	38	50	64	76	100	123	151	202	253
L		108	117	127	140	165	178	190	203	229	356	394	457	533
H		108	111	124	128	134	143	179	189	224	240	315	406	Gear operation
D		130	130	160	160	230	230	400	400	460	460	1000	1500	Gear operation

Valve operator

NPS 1/2 to 8: Lever operation
 NPS 5 to 8: Optional gear operation
 NPS 10: Standard gear operation

Option

- ★ Flexible graphite packing and gasket (See Pages 11 and 43)
- Ball and stem to 316ss available in carbon steel valves upon request

Gear Operation

Unit: mm

Nominal Pressure	Class 150	Class 300	Gear Operator											
			H		D		C		A					
			150	300	150	300	150	300	150	300				
Nominal size (NPS)		4		258		310		165		65.5				
	5		274		254		165		65.5					
	6	6	322	335	310	360	165	210	66.5	88.5				
	8	8	412	412	360	360	210	210	88.5	88.5				
	10		448	—	500	—	363	—	93.5	—				

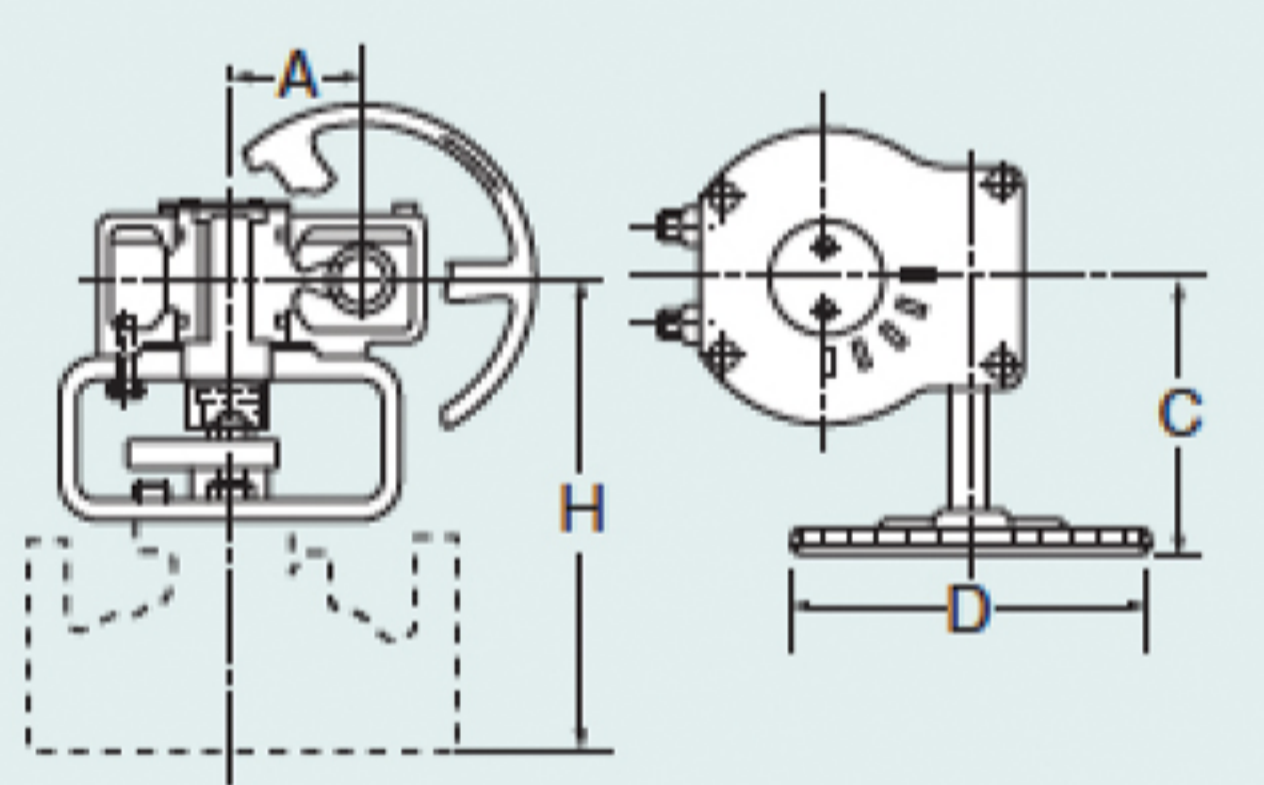

Worm gear operators may be mounted on KITZ ball valves at your option for the smoothest valve operation. Electric or pneumatic actuators are also optionally available. Contact KITZ distributors for appropriate choice and sizing of valve actuators.

Refer to "Product Range" on Page 1.